



GELEX
ALUMINUM BOATS

User's manual

GELEX G440
Light



GELEX
G440 Light

User's manual

Dear Customer!

Congratulations with the purchase of the
GELEX GLOBAL GROUP product.

GELEX boats are the result of leading engineering technologies implementation, integration tests, constant desire to provide an increased level of comfort, reliability, safety and excellent performance specifications.

We are thankful for your choice and believe you'll get unforgettable impressions using our products and it will be the constant source of satisfaction in your life.

GELEX GLOBAL GROUP Team

**ATTENTION!**

Before boat operation, it 's important to read the manual to have a clear vision of the boat construction, its operating parameters and parts, technical systems, installed equipment, capabilities and limitations.

Only qualified stuff must perform maintenance or modify your boat for your safety and boat integrity.

Please note that this manual is not a detailed repair or troubleshooting guide.

For repairs, upgrades or maintenance, please contact our nearest dealer or factory. You can find detailed information and our partners' contacts on our official website www.gelexglobal.com.

This manual is included with the boat and is given to the new owner upon sale. All texts, technical specifications and schematic images in this manual are for guidance only and may differ from the boat you receive after ordering - as we are constantly working to improve and modernize our serial product.

The manual contains recommendations for safe driving, but it is not the purpose of this document to describe all the methods and skills of safe driving.

We strongly recommend that all boat owners take a boating training course to gain knowledge of the mental and physical levels required for safe driving.

This manual is a warranty card and contains information about warranty package of boat manufacturer.

Please read the warranty terms and conditions carefully.

THE CONTENT

1.	HULL IDENTIFICATION NUMBER.....	5
2.	MANUFACTURER'S PLATE.....	6
3.	BOAT DESIGN	7
4.	BOAT'S TYPES AND MAIN COMPONENTS	8
5.	SPECIFICATIONS.....	9
6.	BASIC AND ADDITIONAL EQUIPMENT	10
7.	SWIVEL SEATS INSTALLATION	12
8.	FUEL SYSTEM	13
9.	BOAT POWER SUPPLY SCHEME.....	14
10.	BOAT OPERATION	17
11.	SAFETY RECOMMENDATIONS	20
12.	BOAT LOADING AND TRANSPORTING ON THE TRAILER.....	22
13.	BOAT STORAGE AND MAINTENANCE	23
14.	SYSTEM CHECK	25
15.	WARRANTY PACKAGE	27

1. HULL IDENTIFICATION NUMBER

All GELEX boats come under a standard ISO 6185 established by the International Standardization Organization and EU Directive 2013/53 / EU.

Each hull manufactured at our plant is assigned an individual CIN number. CIN (Craft Identification Number) is the hull identification number of a small vessel which requirements can be found in ISO 10087 standard.

This number is required for boat registration in appropriate authorities and other legal acts (selling, disposition of right, etc). CIN number is necessary for contact the factory for technical service, repairs or warranty handling.

Always indicate the CIN number of your boat, to speed up the resolution of your questions, when contacting the GELEX GLOBAL GROUP Customer Support Service.

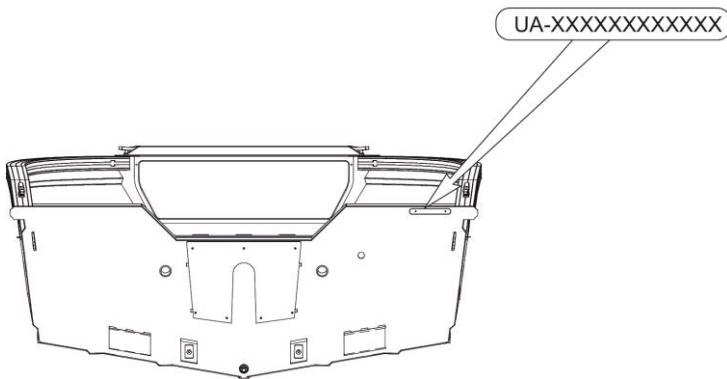

2. MANUFACTURER'S PLATE

The manufacturer's plate is installed on each boat that has a certificate of conformity, it contains the information about maximum-passengers number, load capacity and other parameters. The manufacturer's plate is located on the stern of the vessel.

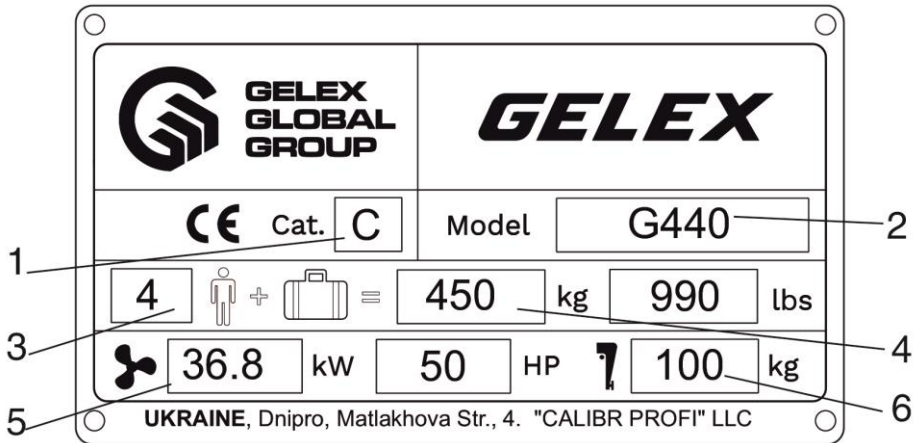

Details of the manufacturer's plate:

- 1 - Ship category (European Directive 2013/53/EU).
- 2 - MODEL: Commercial name of the model.
- 3 - The maximum number of persons allowed on board (adults + children) according to ISO and DIN standards.
- 4 - The maximum load capacity of the boat, allowed by the manufacturer and expressed in kilograms and pounds.
- 5 - The maximum power of the outboard motor, allowed by the manufacturer for the boat and expressed in kilowatts and horsepower.
- 6 - The maximum engine weight, allowed by the manufacturer for the boat and expressed in kilograms.

3. BOAT DESIGN

The hull is made of high-quality marine aluminum alloy EN AW 5083 H111. The hull design is open-type. There are two pairs of redans along the bottom. The keel line is equipped with additional protection. The boat is painted with gray powder paint (RAL 7011) completely in basic equipment.

Chromate-free titanium passivation according to the ENVIROX system is used for aluminum case as additional protection against corrosion. For additional equipment and rubrail mounting, the boat is equipped with a powerful box-type gunwale with a double-sided T-slot. Boat's internal cavities are filled with buoyancy tank which ensures unsinkability and additional vessel safety. In the stern of the vessel there is a self-draining recess and a rigid transom 508 mm height, on which an outboard engine is installed (purchased separately).

BOAT'S TYPES AND MAIN COMPONENTS

Boat GELEX G440 Light general view (with some options):

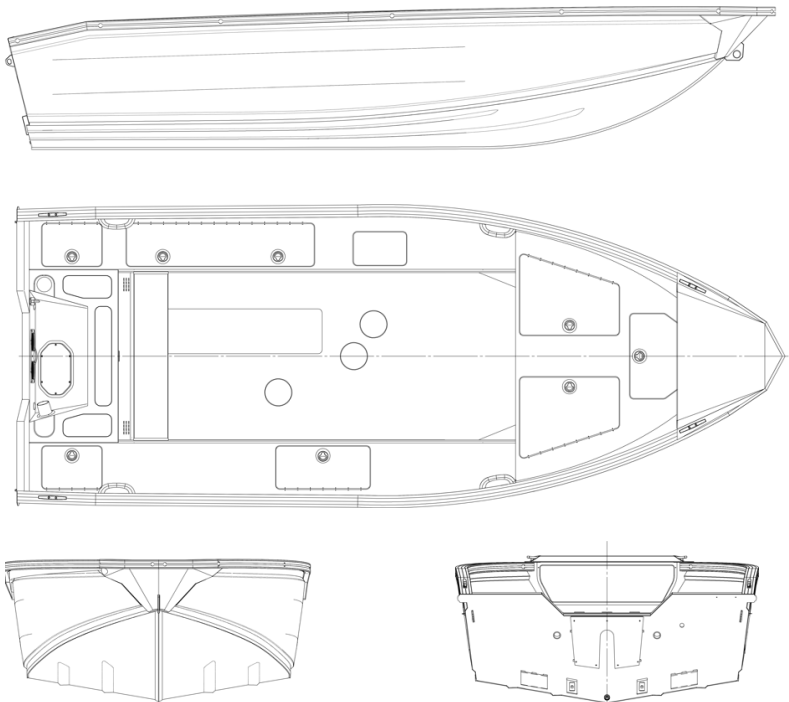

4. BOAT'S TYPES AND MAIN COMPONENTS

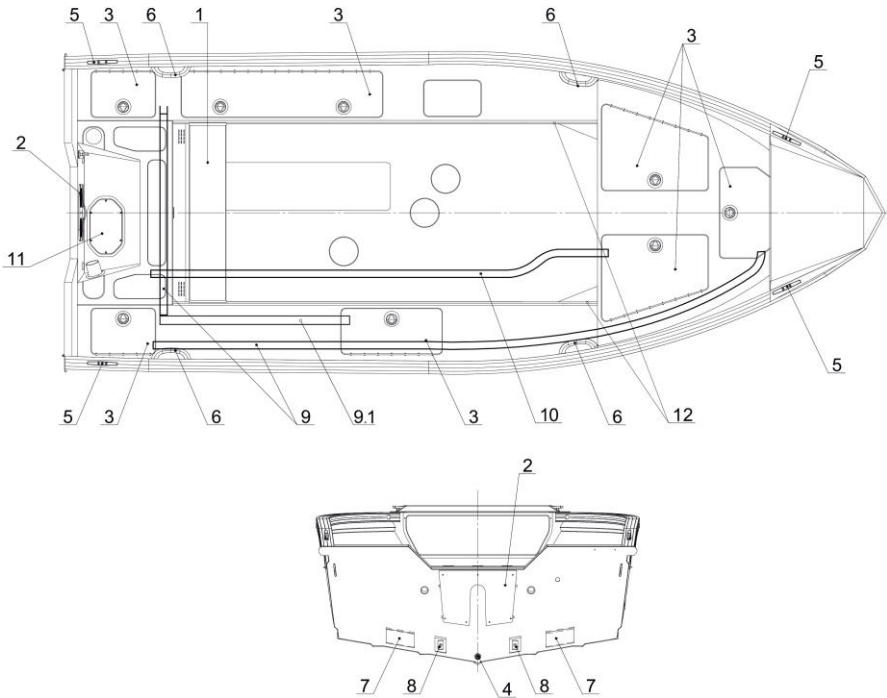

Pic. 1. Main boat's components

1. Under-seat locker-bag (for oars storage) and two folding oars, 2.15 m.
2. Two transom cover (internal – aluminum, external – plastic);
3. Lockers for storing things and accessories (including an anchor compartment);
4. Drainage system (drain plug);
5. Polyamide mooring cleats;
6. Internal on-board handles;
7. Mounting platforms for the echo sounder sensor;
8. Zinc anodes (additional corrosion protection);
9. Cable tray for the electrical kit;
9.1 An auxiliary cable tray;
10. Cable tray under the fuel hose;
11. Inspection hatch;
12. T- slots for fastening movable seats (benches) and additional equipment.

5. SPECIFICATIONS

GELEX G440 Light has the following technical specifications:

<i>Characteristic</i>	<i>Parameters</i>
Hull material	AlMg 4,5 Mn (5083)
Weight	264 kg
Length	4540 mm
Width	1750 mm
Height	780 mm
Transom height	508 mm
Maximum engine power	50 HP / 36,8 kW
Recommended engine power	30 HP/ 22.1 kW
Maximum engine weight	100 kg
Maximum engine weight	450 kg
Passangers' number	4
Deadrise on the middle	14°
Deadrise on the transom	10°
Maximum loading draft	300 mm
Sheet thickness	2,5 mm
Bottom thickness	3 mm
Boat category EC	C

ATTENTION!



The manufacturer reserves the right to make changes to the design and equipment of boats in order to improve their technical characteristics without prior notice.

6. BASIC AND ADDITIONAL EQUIPMENT

BASIC EQUIPMENT GELEX G440 Light:

The basic equipment of the boat includes:

- The hull is completely painted with gray polyester powder paint (RAL 7011);
- Reinforced bow platform with the possibility of installing additional equipment in it (anchor winch, electric anchor);
- T-shaped profile for the installation of movable seats, a sofa and other equipment on both sides of the on-board cockpit niches;
- Insert elements for the rack under the seat - 4 pcs.;
- Hinges of locker covers;
- Stainless locks lockers covers';
- Rubrail - dark gray PVC profile, fixed in the external T-slot;
- Bow cleat - 1 pc., stern cleat - 2 pcs;
- Internal aluminum transom cover - 1 pc.;
- External plastic transom cover-1 pc;
- Mounting platform for installing the echo sounder sensor on the transom - 2 pcs;
- Zinc anodes (additional hull corrosion protection) - 2 pcs.;
- Preparation for the electrical package (cable tray);
- Buoyancy blocks according to ISO 6185 standard;
- Drainage system;
- Lockers:
 - bow self-draining locker-2 pcs,
 - board self-draining locker for things and accessories storage – 4 pcs., (1 of them - for 2 spinnings storing);
 - stern locker-1pc;
 - anchor compartment-1 pc,
- Adjustable internal side handles in T-slot - 4 pcs.;
- Keel protection;
- Polyamide mooring cleats – 4 pc.;
- Folding oars with a storage bag - 2 pcs.

ADDITIONAL EQUIPMENT GELEX G440 Light:

Additional equipment may include:

- Painting the boat hull in a different color, options are available on the website www.gelexglobal.com or at an authorized dealer.
- Pasting the outer sides with decorative plaid.
- Covering the inside of the boat's side with a marine carpet.
- Pasting of the internal surfaces of the cockpit with SeaDeck materials.
- Steering consoles:
 - GC-02 – side console;
 - GC-02L – side console with windshield, railing and shelf for things;
 - GC-03 – central console;
 - GC-06 – side console.
- Mechanical steering system:
 - steering wheel
 - gearbox
 - cable
- Removable railing on the gunwale - 4 pcs.
- Aluminum seats with fixation, with the possibility of adjustment along the entire length of the cockpit.
- Swivel seats.
- Aft adjustable two-seater sofa-platform GS-01.
- Aft adjustable two-seater sofa GS-04.
- Removable soft seats.
- Electric kit for the central console:
 - control panel (shift keys-4 pcs, in reserve – 2pcs)
 - 12 V socket
 - fuse set
 - navigation lights (green, red)
 - navigation lights (white)
 - mass switch
 - battery tray
 - automatic drainage pump
 - horn (depending on the console modification).
- Under-seat locker-bag
- Rowing set: oar holders - 2 pcs., universal lock - 2 pcs.
- Fuel system – stationary tank made of aluminum for 40 l (with fuel level sensor, neck and connecting hoses).

- Mesh pocket for small items-4pcs
- Fishing package: rod holder on inner board – 4 pcs
- Borika Fasten system:
 - a platform with a universal lock - 2 pcs.
 - additional spinning holder - 2 pcs.
 - universal side lock on gunwale - 2 pcs.
 - mounting platform for the echo sounder installation on the gunwale.
 - anchor holder with automatic stop on the gunwale.
- Overall cover.

Updating information on the basic and additional equipment of the boat Gelex 440 Light can be found on our official Web Site

www.gelexglobal.com.ua or from an authorized dealer.



ATTENTION! If you want to install additional equipment on your boat, contact an authorized GELEX GLOBAL GROUP dealer or the manufacturer to get more accurate information what you can do by yourself and what you shouldn't.



ATTENTION! You can run a risk and loose your warranty repair. It is better to entrust installation of the additional equipment to experts and to carry out it only according to the schemes-drawings given below.

7. SWIVEL SEATS INSTALLATION

Embedded element's scheme

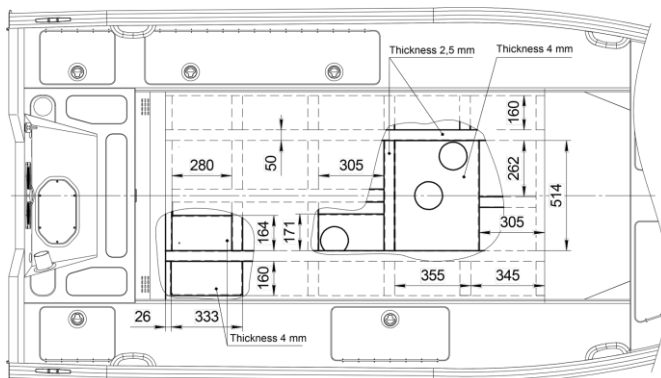

This scheme of embedded elements placement on the deck is presented for the correct positioning of the pillars of the swivel seats during their installation.

8. FUEL SYSTEM

Gelex G440 Light can be fitted with a stationary fuel tank of 40 liters and a mobile fuel tank of up to 25 liters. The mobile fuel tank can be located both in the bow compartment and in the stern. The manufacturer provided special mounting channels for the fuel tank hose as shown in the picture below.

LOCATION OF THE FUEL TANK IN TWO POSITIONS

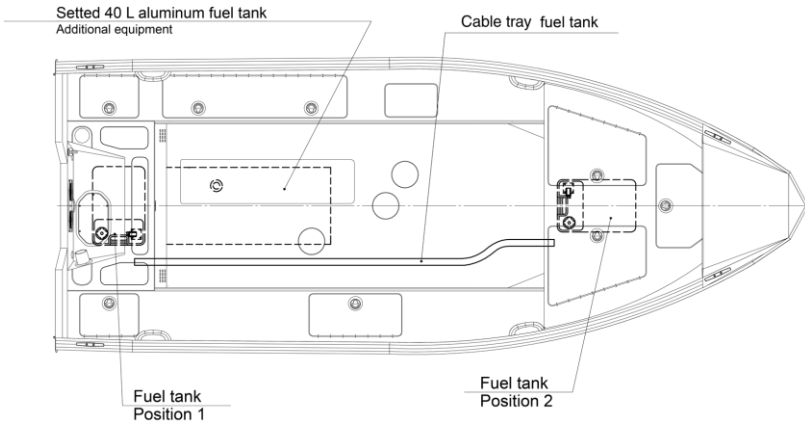

Position 1. To place the fuel tank in the stern compartment of the boat, it is necessary:

- Route the fuel hose through the cable tray through the seal to the engine.
- Connect the fuel hose to the engine fuel fitting with a stainless steel clamp.
- Place the fuel tank under the recess.
- Connect the fuel hose to the fuel tank.

Position 2. To place the fuel tank in the bow of the boat, it is necessary:

- Route the fuel hose through the cable tray located under the deck (parallel to the DP line).
- Then route the fuel hose through the cable gland and out to the engine.
- Connect the fuel hose to the engine fuel fitting with a stainless steel clamp.
- Place the fuel tank in the bow box.
- Connect the fuel hose to the fuel tank.

PROCEDURE FOR REFILLING WITH FUEL

1. If the tank is mobile, remove it from the boat before filling.
2. If your outboard requires a mixture of gasoline and oil - follow the engine's operating instructions to mix the oil with gasoline correctly and obtain the correct proportions of gasoline and oil.
3. Clean up any spilled fuel thoroughly before returning the tank to the boat.
4. Some portable fuel tanks have vent screws that must be open when the engine is running - pay attention to this!



WARNING! Do not use fuel that contains alcohol in any form or its derivatives or ethanol. Alcohol and ethanol can damage hoses and fuel system components, which can lead to dangerous leaks, fire or explosion.



WARNING! If fuel is spilled on painted or decorative surfaces of the boat during refueling, rinse them with water and wipe the areas with a dry cloth or paper towel to prevent damage to the decorative coating.

During long-term parking or winter storage indoors, it is forbidden to store combustible or flammable liquids

9. BOAT POWER SUPPLY SCHEME

The basic configuration of GELEX G440 Light provides for the placement of special cable tray in the case for conducting wires and connecting all elements of the power supply circuit (see pic. below).

*The cable channel of the central console can be installed only if it is available.

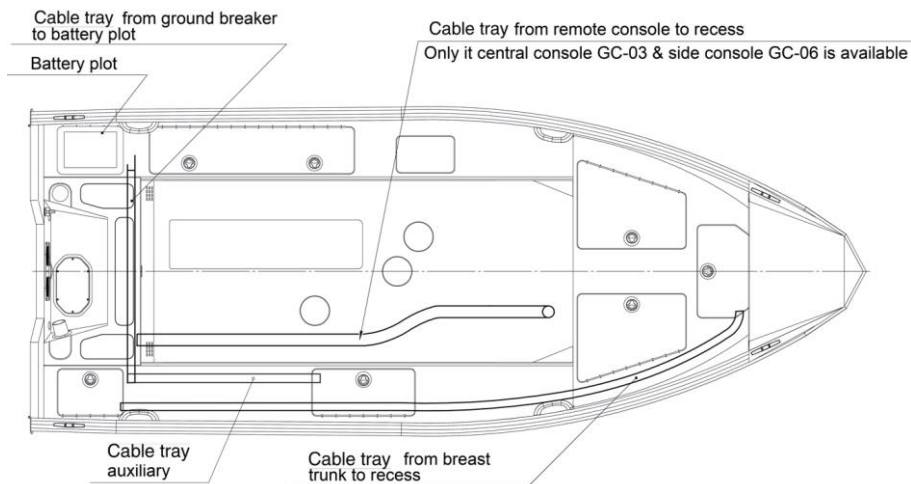

Also, all Gelex G440 Light models can be equipped with an electric kit (see section Additional equipment Gelex G440 Light)

LIST OF ELEMENTS OF ELECTRICAL SCHEME BOAT WITH CONSOLE GC-03 and GC-06*

#	Marking	Name	Quantity
1	F1	Fuse for the horn	1
2	F2	Bilge pump fuse	1
3	F3	Fuse of navigation light	2
4	F4	Backup keys fuse	1
5	F5	Socket fuse	1
6	F6	Enclosed automobile fuse	1
7	XS1	12 V socket	1
8	SA1	Key for horn	1
9	SA2	Bilge pump key	1
10	SA3	Navigation light key	1
11	SA4	Reserve key	1
12	EL1-EL2	Navigation lights	2
13	EL3	Parking top light	1
14	M1	Bilge pump	1
15	P1-P2	Station	2
16	SB	Earthing device	1
17	GB	* Battery	1
18	FT	Fuel tank**	1
19	HORN	Horn	1

* Battery sold separately

ATTENTION! We do not advise you to make any changes to the boat's standard electrical circuit yourself. If this happens, the manufacturer removes responsibility for its further functioning. To carry out such work, we advise you to contact the nearest authorized dealer of the company or the manufacturing plant. Depending on the power of the engine installed on the boat, as well as other additional equipment (electric anchor winch, electric motor, navigation equipment, echo sounders, etc.) - choose only the appropriate type, size and capacity of batteries, as well as the appropriate size of wires for their connection.



ATTENTION! Charge batteries and maintain them in a timely manner, do not store and operate the boat with discharged energy carriers.



10. BOAT OPERATION

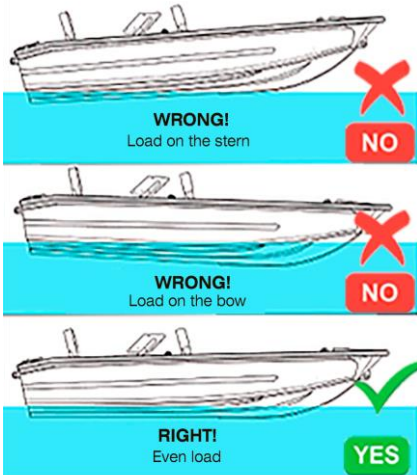

Using the boat in unfavourable conditions or beyond the design restrictions may affect to its condition and cause the warranty loss. To operate the boat you need Vessel Driving License, certain knowledge, skills and experience. After training at special courses you can get it. About the enrollment for such courses and the training conditions you can find out in your city or from the nearest authorized GELEX GLOBAL GROUP dealer. Before your first boat trip, you should make sure that the boat is ready to launch, all systems are working properly, and weather conditions do not pose a threat to travel (get a reliable weather forecast from several sources).

Before leaving the shore or pier - follow these steps:

- Check engine operation and vessel equipment (bilge pump, navigation lights, echo sounder, navigation equipment and radio station) one more time if this equipment is installed.
- Check steering: turn the rudder until it is fully locked clockwise and counterclockwise to allow the boat moving free.
- Inform a responsible friend or relative about your intended water trip. If you return or change anything in these plans, inform these persons again - in order to avoid unnecessary misunderstandings and anxiety of people who care about you.
- Make sure all passengers are wearing life jackets and seated.

ATTENTION! REMEMBER, during the movement it is forbidden to stand in a boat or move in a boat in any direction!



- Be sure that your health allows you to make this journey. Never take alcohol, drugs or even prescription drugs before or during the trip. Your illness, inattention or vice versa great excitement can lead to an accident or injury you or your passengers!
- Make sure that all your things inside the boat (bags, clothes, bottled water, fishing tackle, etc.) are properly fixed in the appropriate places, and after the start they will not move in the cockpit to disturb you, and wont fall overboard.

- Try to concentrate the load in the boat as evenly and low as it's possible. In the cockpit place things so they don't move and slip when your boat is moving. Do not exceed the maximum load capacity loading the boat.

After completing all checks - you are ready to go out on the water. Remember that the boat has no brakes, it stops only by inertia as soon as it decreases. It is also possible to brake the engine at low speed (no more 10 km / h) - including reverse. Be sure that the steering wheel is not turned to the extreme position, to the left or right, such an extreme maneuver can be very dangerous and lead to a dangerous transverse trim.

All maneuvers must be foreseen by you, with no sudden and quick movements unless the situation requires it.

Remember that water is an aggressive environment and it does not forgive any mistakes.

After moving away from the shore or pier take some time to learn maneuvering and get used to the size of your boat, its capabilities and features.

Practice turns at low speed, moving forward and backward, stopping the boat, and you need also practice mooring.

Basic maneuvering principles

Basic principles of maneuvering with remote control

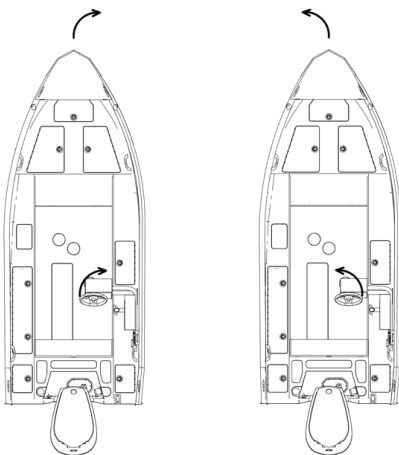

Basic principles of maneuvering with tiller control

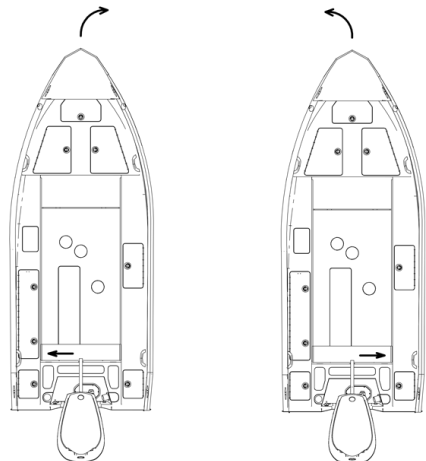

Adjusting the tilt of the engine for maximum performance

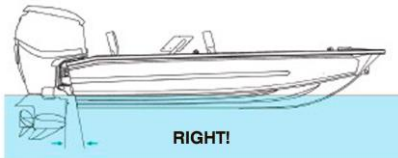
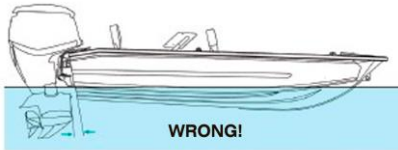
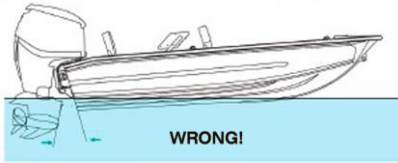

Proper mooring requires preparation. Consider the wind and the speed/direction of the current - these have a big impact on the movement of the boat as a whole, especially when mooring or docking maneuvers. In strong winds and waves, try to move against them for a safer and more predictable mooring. Make sure you have enough mooring equipment that is properly stacked and ready to use. Your dealer is the best source of information about the amount and type of equipment you need to have.

Optimum engine performance is fuel economy and efficiency of the boat in general. We advise you to

determine your optimal mode and cruising speed of the boat as soon as possible for optimal use. Mostly, out-board engines provide the best fuel economy around 4000-5000 rpm, try to use the engine in this range during your trips to any distances. Boat loading also effects on fuel economy, so do not fill the boat with unnecessary things. The speed is affected by the diameter and screw pitch. Diameter is applied to the circle, which is described by the outer edges of the blades, the unit of measurement - inches. Screw pitch is the distance that the screw travels in the axial direction in one revolution.

For example, a screw with a 21 inches step moves 21 inches through the water when rotated 360 degrees. Under the influence of pressure and sliding of the blade angle, the screw can not move further than about 90%, depending on the number of steps, usually it does not exceed 80-85%.

Screw diameter

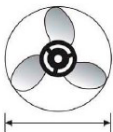

Screw pitch

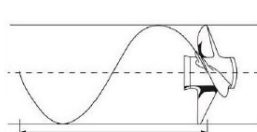

! A damaged screw must be replaced as soon as possible with a suitable one and in working order!



The screw must not show significant damage, excessive deformation, or any distortion that alters the original design. Operation of a boat with a damaged screw reduces its maximum speed, increases fuel consumption, creates unpleasant vibrations, and this in turn accelerates the wear of rotating and piston engine parts and can lead to loss of boat controllability.

The hull must be at 3 to 4 degrees angle to the water for maximum efficiency. If your boat is moving with the bow too high or too low at cruising speed, then you must distribute the load in the boat more proportionally by moving some of it to the bow or stern of the boat. If it doesn't help you should adjust the engine angle. See engine owner's manual for more information on adjustment.

To achieve the best boat and engine performance, the optimum engine angle should be set as it's given in the guidelines or according to the prevailing conditions.

Passengers and equipment in the boat must be placed so that it is evenly balanced from bow to stern, and port and starboard.

11. SAFETY RECOMMENDATIONS

We remind you some basic rules during water trips:

- Be responsible and never disregard safety rules.
- Take under control what happens in and around the boat. As the owner of the boat you are responsible for your own safety, your passengers safety and for following all safety recommendations.
- Be polite and respect other water users.
- Follow all local rules, laws and conventions.
- Near the shore stay only in special places for boats.
- Always make sure you can get back to your parking - keep an eye on fuel consumption and weather conditions.

Perform regular system checks of the boat and its mechanisms: hull, engine, fuel system, batteries, steering system, etc.

You must be sure that your boat and all of its systems are in a safe and working order. Please note that according to the laws and regulations of navigation, you must maintain life-saving appliances for all crew members.

Refer to the local laws and regulations in your country to get a list of necessary and life-saving equipment that must be on your boat.

We remind you that driving a motorboat while intoxicated or under the influence of drugs is strictly prohibited by law. The consumption of alcohol and drugs reduces the reaction, impairs your perception and assessment of the situation, endangers you and your passengers, as well as other water users and vacationers.

ATTENTION!



Deliberate violation of safe recommendations of the boat using may void the warranty. The loads caused by towing are beyond the design requirements of our boats.

DO NOT tow your boat or use your boat to tow other boats!

Boat damage as a result of towing or being towed by another boat is not covered by the warranty.

**READ AND REMEMBER BASIC SAFETY RECOMMENDATIONS:**

1. Put on life jacket being on the boat.
2. Always use an emergency cord-switch: wear it around your wrist or attach it to your clothes.
3. No alcohol or drug use during vessel driving.
4. Don't exceed the permitted number of persons and don't overload your boat.
5. Before starting the movement, make sure that your passengers are sitting in their regular seats, warn everyone about the start.
6. Be especially careful when mooring: arms and legs can be injured if they are overboard.
7. Stay away from swimmers and divers, avoid places where divers and swimmers are in the water. Take control over it, especially when you are near beaches and launching areas. Turn off the engine when you are near such places.
You must keep a sufficient distance (50 meters minimum).
8. Avoid sharp turns at high speed, you or passengers may be thrown out of the boat.
9. Don't change your movement direction without passengers warning.
10. Don't speed or race. Maintain the optimum speed to avoid losing control of the boat.
11. Accumulator warning:
 - Avoid sparks and open flames near the accumulator, it can explode.
 - Protect the positive terminal of the battery from short circuit or contact with any metal objects.
 - The engine must be turned off when inspecting or servicing the battery. Turn off the battery disconnect switch when leaving the boat for a long time.
 - Never keep the battery near a fuel tank, filler port, or fuel system components.
12. Inspect and maintain the control system: if this system is not serviced properly, it may fail, causing a sudden loss of the boat control.
13. All electrical appliances in the boat must correspond to the electrical circuit current. The boat's electrical system must be serviced only by a qualified technician.
14. Avoid Explosion and Fire Hazards: Make sure your boat's fuel system is in good condition, free of leaks and smells of fuel, and keep it in good condition.
15. No smoking on the boat.
16. Stop operating the boat if you notice a fuel leak or smell of fuel until the cause is found and corrected.
17. Self-modernization or modification of the boat and its systems will not only terminate the Manufacturer's Warranty, but may also result in structural damage, galvanic or involuntary corrosion, as well as other technical threats.

12. BOAT LOADING AND TRANSPORTING ON THE TRAILER

To transport the boat, choose the appropriate trailer that is most suitable for the weight and dimensions of the boat. The size and capacity of the trailer must match the size and weight of your boat. Contact your nearest authorized dealer to get an information on what trailer to buy.

Your boat can be lifted in this way:

1. Reduce the speed approaching the shore.
2. Switch off your engine and continue moving on the shallows. The boat will reach the lift by inertia, moving along the central axis of the trailer that should be drowned under water to a depth that covers the stern runners or rollers.

Set the winch to reverse mode and drag the lines back. Guide the boat towards the trailer, line up and fasten the lines to the bow of the boat.

3. Straighten the boat, directing it to the trailer, while your assistant pulling the boat by a winch.

4. Pull the boat completely onto the trailer to avoid irregular transport wheels loading.

If you meet some difficulties arranging the boat on the trailer, back to the deep water and install your boat again.

To fasten the boat to the trailer, use special straps that will securely fix it through the eye-brackets from the bow and stern

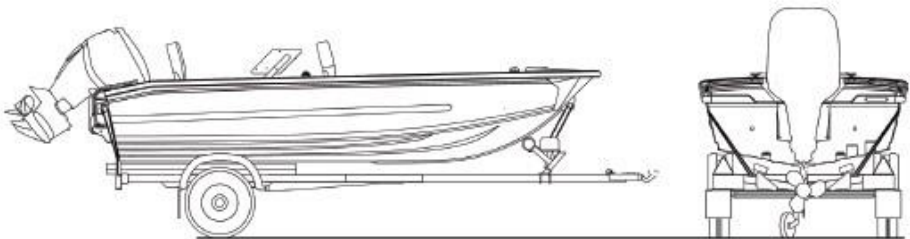

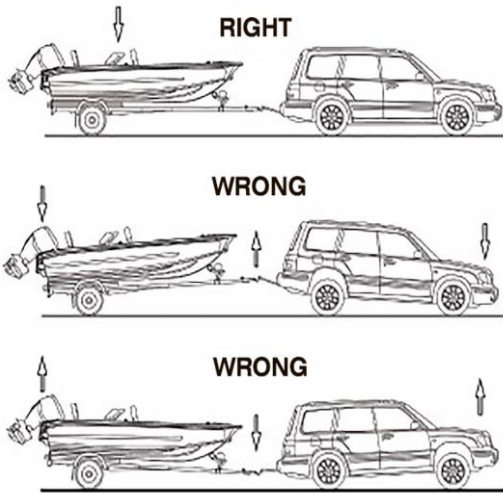

From the front, the boat must also be fixed through the eye-bracket using the drum winch cable. Always adjust the position of the straps to keep the boat level while pulling up, providing protection between the straps and the hull. The boat on the trailer must be placed evenly, without transverse and longitudinal distortions. You must be sure that the weight of the boat is evenly distributed throughout its length and width (see picture), and the boat with its hull lies flat on the lodgements.

If the boat weight is correctly and evenly distributed on the trailer, the load on its hitch device should be 30-50 kg within, it should be your guideline. Otherwise, excessive weight on the hitch device, or unevenly located on the lodgements of the boat – may result in loss of car control and to an accident. Note that your outboard may also require a special stop. Don't forget to check all fastenings of an overall cover - incorrect or insufficient fixing can lead to its damage. The speed of the car, when transporting a trailer with a boat, should not exceed 80 km / h.

13. BOAT STORAGE AND MAINTENANCE

We recommend you to pay maximum attention to the proper storage and care of the boat - under such conditions, you will not only retain its attractive appearance, but will also have less repair and maintenance costs.

Below we provide a list of tips for storing and caring for your boat and its systems, but it is not exclusive and may expand.

Don't keep your boat on the water near the piers with iron walls, especially without taking any measures to prevent electrochemical corrosion.

The boat must not be kept on the water for too long, otherwise its hull will be overgrown with aquatic plants and other aquatic microorganisms. It will cause faster wear of the underwater part of the hull and its parts, as well as reduce speed. Periodically lift the boat ashore and rinse the hull with fresh water to wash away plaque and growths.

Do not use chemically active reagents to wash the boat, both the outside of the hull and the inside. Do not use benzine or various paint removers (benzene, acetone, turpentine, varnish remover, or any of the following ingredients) to remove dirties from painted surfaces.

Also, do not use any form of acid to remove dirt or to wash the boat. It can damage not only the painted coating, but also damage the boat parts.

Exclude the impact on the hull and embellishments of the following substances:

- Gasoline, fat, oil or any other oily product.
- Tanning oils, lotions and any other body care products.
- Substances that pollute the environment and create dirt and dust.
- Silicone-based products, automotive chemicals.

To maintain the boat appearance, it is necessary to take care of it in regular maintenance, using appropriate procedures. Always maintain the boat in accordance with any relevant pollution control regulations. Choose cleaners carefully to make sure they do not contain corrosive substances.

Water with suitable wash is the best for boat washing.

After each use of the boat, be sure to ventilate and drain all lockers and enclosed spaces. Some of the boat's lockers have ventilation holes, but you should not rely on them completely - excessive moisture and debris that stays there for a long time can lead to mold, microflora and, as a result, an unpleasant odor.

You can use dry cloths. After placing the boat in the parking lot or on the pier for a long time, we recommend leaving the covers of the lockers a little ajar.

Winter storage and conservation of the boat is a very important process. To prevent damage and rapid wear of the boat hull and its systems, we recommend the following steps to prepare it for winter storage:

- Fix the bow of the boat a little higher than the stern - to drain as much water as possible.
- Open a drain plug and drain all the water that could come inside.
- Remove from the boat anything that may retain moisture and cause mold (rags, paper, foam, etc.).
- Wash the boat thoroughly, dry all surfaces and all lockers.
- Disconnect and remove all batteries, charge them, and store them in a dry, well-ventilated place 0 ° C above.
- Make sure that the boat and all its lockers are dry and air can freely enter them.
- Check the integrity of the overall cover, all its fastenings and ties.

A damaged overall cover can leak moisture, sediments and later with sudden temperature changes (frost), this water can damage the hull of the boat. If you live in heavy snowfall area - we recommend to store the boat only under a overall cover.

The boat structural elements and systems are affected by the sea water and because of this salt crystals can be formed on the frames and plastic covers. This plaque should be removed with a soft damp cloth. Never use abrasives or coarse, dirty cloth to wipe plastic parts. Neutral household detergents and plastic cleaners can be used to maintain the shine and cleanliness of appliances and the instrument panel / switches.

Overall covers are made of textile which is covered a water-repellent coating on the front side. This material is generally not susceptible to mildew, but it may have residual organic matter on it, so overall covers should also be carefully looked after.

The textile can be cleaned without removing it from the frame, the residual dirt can be washed off using soapy liquid or neutral cleansers.

Overall covers should only be stored dry!

Remove all seats regularly, and clean them thoroughly, especially at the attachment points. If the seats are not removed for a long time, the fasteners oxidize and this leads to difficulties in using and removing them. To clean the seats, we recommend using wet wipes specially designed for cleaning, which successfully clean the surfaces from dust, sand and dirt.

Use special cleaners to remove stains and other persistent foulings. For plastic care and stainless steel parts, use only specially designed liquid cleansers and soft cloths to clean the dirt. Do not clean with mineral acids or bleaches! Also, do not allow stainless steel to come into constant contact with other metals, which can cause fouls that will later lead to rust or corrosion. If it's necessary, later you can use special mastics for metal and stainless steel to restore shine.

14. SYSTEM CHECK

The design and built-in systems of the boat need regular system checks. Do not neglect these tips - this will save you money and time, as well as save you from unplanned repairs.

If you keep your boat on the water all around the year, you should raise it at least once a year. You should check the hull for damages, all systems should be checked and cleaned for safe operations.

Regularly inspect all interior surfaces of the boat (bow deck, cockpit, railings, stall covers, etc.) for loose screws, chips, sharp or protruding edges - this can be dangerous and cause injury.

DO NOT use an open flame or 220V lighting fixtures to inspect the hold space.

Carry out inspection only when the on-board power supply circuit is disconnected! Strictly observe fire safety measures.

It is necessary to pay attention to all fasteners, hoses, fittings, fuel filters, fuel system reservoir. Signs of possible malfunctions in the fuel supply hose to the engine are cracks in the places where the clamps are installed, swelling of the hose, unstable engine operation associated with air entering the system, and small debris entering the fuel tank intake.

If there are kinks and cracks on the surface of the fuel hoses, they must be replaced. The warranty period of most fuel system components is about two years so it is necessary to replace the fuel hoses every two years.

Pay attention to the operation of electrical equipment. Sparking of contacts, damage

to wiring insulation is unacceptable. Periodically check the battery mounting system. Check batteries regularly for signs of corrosion. If corrosion is obvious, clean the terminals with a wire brush and an aqueous solution of baking soda. Batteries have a limited life span and can be discharged. If you use the boat infrequently and with long breaks, it is necessary to charge the batteries periodically.

Check all equipment, alarm equipment and life jackets for serviceability. Before water trip, inspect the anchor, mooring and towing rope, repair them in time or replace them if it's necessary.

Periodically check the steering system for smooth, free and full travel. Also, check the original self-tightening nuts that are used to secure the steering link between the gear cable and the engine.

The hull of the boat is made of high-quality marine aluminum alloy recommended for use in salt water. To protect against corrosion, the boat is equipped with two replaceable zinc anodes. Inspect the anodes regularly. If traces of dissolution are visible on the anodes and they have lost more than half of their original volume replace them with new ones.

15. WARRANTY PACKAGE

GELEX boats and all structural elements have a limited 3-year warranty. For fittings, hinged equipment and soft kit - the warranty period is 1 year. Some items of boat equipment have a separate warranty, the duration of which may differ from the general warranty period of the boat.

For all warranty issues, please contact the authorized dealer, where the boat was purchased, or the GELEX GLOBAL GROUP manufacturing plant if the purchase of the product was made through the head office.

The manufacturer guarantees the repair and elimination of design flaws, a structural defect in the material or deficiencies in the quality of work if they are identified and fixed by an authorized dealer or manufacturer of GELEX GLOBAL GROUP within a period not exceeding thirty-six calendar months from the date of sale of the boat

Warranty conditions:

1. All warranties and conditions under the Sale of Goods Act, including those of merchantable quality, are not excluded by this warranty, except that GELEX GLOBAL GROUP limits its liability for breach of:
 - unauthorized modification of the boat or its parts;
 - repair of the boat or products, without the consent of an authorized dealer or manufacturer of GELEX GLOBAL GROUP.
2. GELEX GLOBAL GROUP constantly improves its products and cares of high product quality. The service life of GELEX boats exceeds 10 years, so we advise our customers to care the boat, don't overload it and service it in a timely manner so that your boat serves you not only during the warranty period, but for many years later.
3. Any work agreed with repair by GELEX GLOBAL GROUP, or an authorized dealer, will be carried out at the territory of an authorized representative. The warranty conditions do not include the cost of transporting the boat to the place of repair and back.
4. The boat must be used only in accordance with the intended use and according to the category of the vessel, within the technical characteristics specified by the manufacturer and the necessary maintenance instructions attached to the boat.
5. Some items of boat equipment have a separate warranty, the validity of which may differ from the general warranty period of the boat.
6. If the boat is sold or alienated legally during the warranty period, the boat warranty obligations remain unchanged and accrue from the date of sale to the first owner.
7. The warranty does not cover costs incurred due to inconvenience or loss of profit, and any subsequent costs other than warranty repairs to the boat itself.

The warranty doesn't cover:

1. Damage caused by misuse, accident, galvanic corrosion, improper transportation, negligence, neglect of operation and maintenance.
2. Installed engines, electrical appliances of the engine and its components, and damage caused by the installation of the engine or its components.
3. Accessories and additional equipment that are not part of the boat, as well as damage caused by their use.
4. Damage to the windshield, leakage, fading and fading of paints, fabric awnings and upholstery.
5. Water damage, rot, condensation, absorption of internal surfaces, damage to the wooden structure and buoyancy blocks.
6. Boats that have been misused and exceeded performance, i.e. used for racing and competition, rented, used for commercial purposes, used to tow skiers and other vehicles, etc.
7. Boats for which the manufacturer's recommendations for the power and weight of the installed engine and other equipment have been exceeded.
8. Boats that were used without special equipment installed at the manufacturing plant.
9. Damaged boats during loading, transportation and unloading from the trailer, cradle, other devices intended for lowering / raising from the water or transportation and storage.
10. Boats used against law in concrete country.
11. Boats affected by an accident, natural disaster and compelling force.

GELEX
ALUMINUM BOATS

visit us at:
www.gelex.boats

